

BASSOON FINGERING CHART

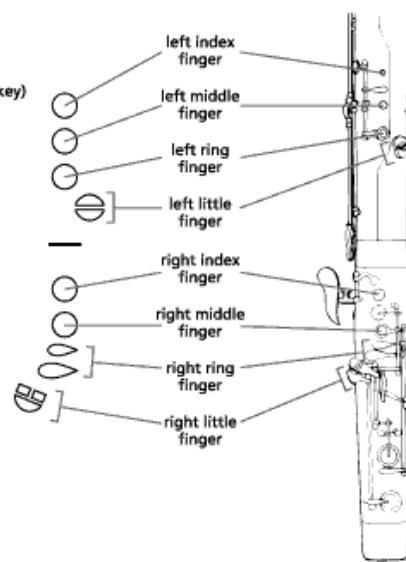
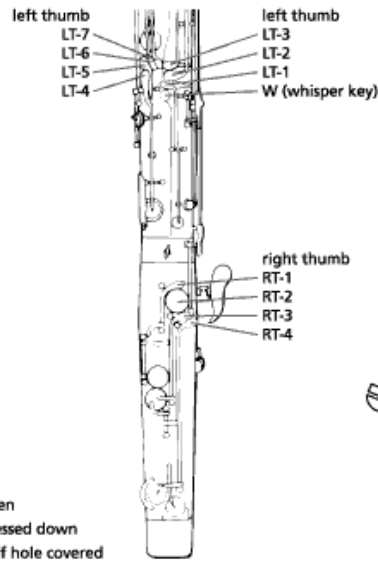

- = open
- = pressed down
- ◐ = half hole covered

B ^b	B	C	C [#]	D ^b	D	D [#]	E ^b		
LT-7 ● LT-6 ● RT-2 ●	LT-6 ● RT-2 ●	LT-5 ● RT-2 ●	LT-5 ● RT-2 ●	LT-4 ● RT-2 ●	LT-4 ● RT-2 ●	LT-4 ● RT-2 ●	LT-4 ● RT-2 ●		
E	F	F [#]	G ^b	G	G [#]	A ^b			
RT-2 ●	W ●	W ● RT-3 ●	W ● or RT-3 ●	W ●	W ●	W ● or RT-4 ●	W ● or RT-4 ●		
A	A [#]	B ^b	B	C	C [#]	D ^b			
W ●	W ● or RT-1 ●	W ●	W ●	W ●	W ●	W ● LT-1 ● LT-4 ●			
D	D [#]	E ^b	E	F	F [#]	G ^b			
W ●	W ● or RT-1 ●	W ● or LT-1 ●	W ●	W ●	W ●	W ● or RT-3 ●	W ● or RT-3 ●		
G	G [#]	A ^b	A	A [#]	B ^b	B	C		
W ●	W ● or RT-4 ●	W ●	W ●	W ● or RT-1 ●	W ●	W ●	W ●		
C [#]	D ^b	D	D [#]	E ^b	E	F	F [#]	G ^b	G
LT-1 ●	W ●	W ●	W ●	W ●	W ●	W ●	W ● * RT-1 ●	W ● * RT-1 ●	W ●

*On some bassoons, high F[#]/G^b can be played more in tune by adding the left hand 3rd (ring) finger to one of the standard fingerings.